



Version 1.0
February 2003

Solar powered pump for swimming pools, agriculture and more

APPLICATIONS

Swimming Pools
Agriculture
Pond management
Fountains, waterfalls

BENEFITS

Non-battery operation
Brushless motor
AC backup optional

SunCentric P uses solar-electric power to pump water. It is cost-effective for swimming pools, especially where utility rates (or daytime peak rates) are very high. A pool pump is often one of the largest electrical loads in a home. A solar pump is practical because the need for filtration is greatest during sunny weather. It is perfect for pumping through solar heat collectors because the circulation requirement corresponds with solar intensity.



FEATURES

- glass-filled polycarbonate construction
- resistant to chemicals, salt and sunlight
- withstands temperatures to 175°F
- quick-disconnect unions
- large basket strainer with clear cover
- self-priming centrifugal design
- internal reservoir to resist dry-run damage
- easily serviceable, with all reusable o-rings
- industrial standard carbon-ceramic shaft seal
- ETADRIVE® brushless motor is ultra-efficient and maintenance-free
- ETADRIVE® soft-start controller optimizes motor efficiency under all conditions

POOL PUMP INTEGRATED SYSTEMS

Standard packages include a *SunCentric P*, the appropriate solar array, disconnect switch, and illustrated instructions. Systems are sized to circulate the full volume of the pool about every 1.5 days in clear weather. Performance estimates are conservative because our precision pump sizing results in lower pressure losses than in conventional systems in which the pump is usually oversized. In cloudy weather the pump runs slower, but still provides sufficient circulation for typical residential use.

Solar tracking option Systems can be selected either with or without tracking. A solar tracker automatically aims the solar array at the sun throughout the day. The extended daily pumping period allows the use of a smaller solar array for a given application. The overall cost is lower. The tracker's drive is non-mechanical (passive) and highly reliable, using only the flow of fluid against gravity. Before selecting a system, decide if tracking is feasible. It is NOT feasible if the solar array is to be mounted on the roof of building or in an area of foot traffic on a pole less than 10 feet (3m) high.

Dimensions (inches)

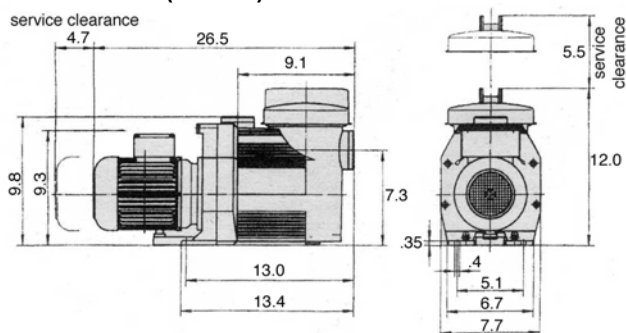

- Controller dimensions: 16 X 12 X 6.5
- AC power pack (optional): 16 X 12 X 6.5

- Solar array (approximate):
340 watts: 34 square feet
480 watts: 48 square feet
600 watts: 60 square feet

Pipe fittings

- ABS quick-disconnect swivel unions, slip-connect to ABS or PVC pipe using ABS/PVC cement
- Intake: 2"
- Outlet: either 1 1/2" or 2"

Shipping weight (approx.)

- pump and motor: 24 lbs (11 kg.)
- controller: 16 lbs (8 kg.)
- AC power pack: 33 lbs (15 kg.)

Accessories

- Fixed PV Array Rack (specify pole-top, adjustable angle roof/ground mount, or fixed-angle roof/ground mount)
- Tracking PV Array Rack (pole-top only)
- Ground Fault Interrupt (required by NEC for installation on a roof), Item# 87026
- Solar array combiner box, Item #87250
- AC Power Pack

AC Power Pack (Item #11930)

If backup power is required, the Power Pack will power the pump from utility service or a generator. The pump can draw from the solar array and the Power Pack simultaneously, drawing solar power as priority. REQUIRED for California CEC rebate.
 Input: 115/230 VAC, 6/3A maximum

Suction capacity

10 vertical feet above water source, at sea level (subtract 1 foot per 1000 ft. elevation)

SWIMMING POOL INTEGRATED SYSTEMS								
TOTAL DYNAMIC HEAD feet	or BACK Pressure psi *	SOLAR ARRAY peak watts	Performance with FIXED ARRAY		Performance with TRACKING ARRAY		peak flow GPM	SYSTEM NUMBER for pump + solar modules
			gallons per day	max. pool volume**	gallons per day	max. pool volume**		
6.5	3	340	17,600	25,100	26,600	38,000	46	37820
		480	23,400	33,500	35,400	50,600	57	37822
		600	27,500	39,300	39,600	56,600	63	37824
13	6	340	11,100	15,900	16,900	24,200	37	37820
		480	17,200	24,500	26,000	37,200	50	37822
		600	21,100	30,200	31,700	45,300	56	37824
20	8.5*	340	6,400	9,200	9,800	14,000	29	37820
		480	11,600	16,500	17,500	25,100	42	37822
		600	16,100	22,900	24,300	34,700	50	37824
26	11	480	6,400	9,100	9,700	13,800	32	37822
		600	10,300	14,800	15,700	22,400	42	37824

* 8 PSI is typical back pressure in a system that is sized according to this selection table. Low-friction (2") piping and a large filter can reduce it further.

** Max. pool volume is based on a turnover of 70% of pool volume per day. For faster turnover, choose a higher volume system with tracking, if possible.

Daily volume is based on solar irradiation of 6 peak sun hours per day.

Daily volume and flow are based on 17% degradation of the array output due to heat, dirt, and tolerances.

Manufacturer's warranty

Pump, motor and controller is 2 years, solar modules 20 or 25 years.

AVAILABLE FROM



For applications outside the range of this product, ask about SunCentric "classic" (cast iron) and other Dankoff solar pumps.

Dankoff Solar Products, Inc.
 Solar pumping since 1983